

Backplate Holdfast (BPH)

Application:

It is used when the installation requires the tape to be secured 75mm away from the face of the building.



Structure Outline:

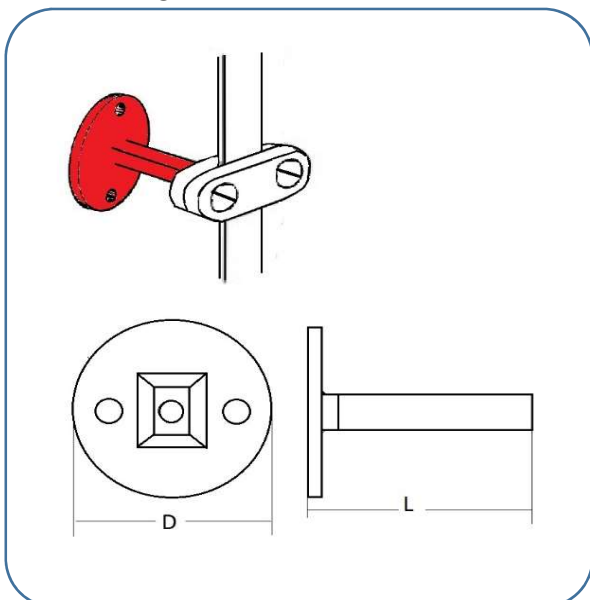

Specification:

For use with appropriate DJC tape clip.

Ord. Code	Lenght (mm)	Diameter (mm)	Box. Qty	Weight (Kg)
BPH 75	75	65	10	0.35

These Metallic Tape Clip are from comercial brass.

Titel:	Document No.:					
Backplate Holdfast (BPH)	Rev.:	0	Issued For Approval	97/10/20	K. J.	M.R.Hedayati
	Page:	1/2	Description	Date	Prepared	Checked
						Approved